

PL INSTRUKCJA MONTAŻU ŚCIANKI AKUSTYCZNEJ CELL – **CES-L-8**, 1600 x 800 mm

EN CELL ACOUSTIC WALL INSTALLATION INSTRUCTIONS – **CES-L-8**, 1600 x 800 mm

DE MONTAGEANLEITUNG FÜR AKUSTIKWAND CELL – **CES-L-8**, 1600 x 800 mm

RU ИНСТРУКЦИЯ ПО МОНТАЖУ АКУСТИЧЕСКОЙ ПЕРЕГОРОДКИ CELL – **CES-L-8**, 1600 x 800 мм

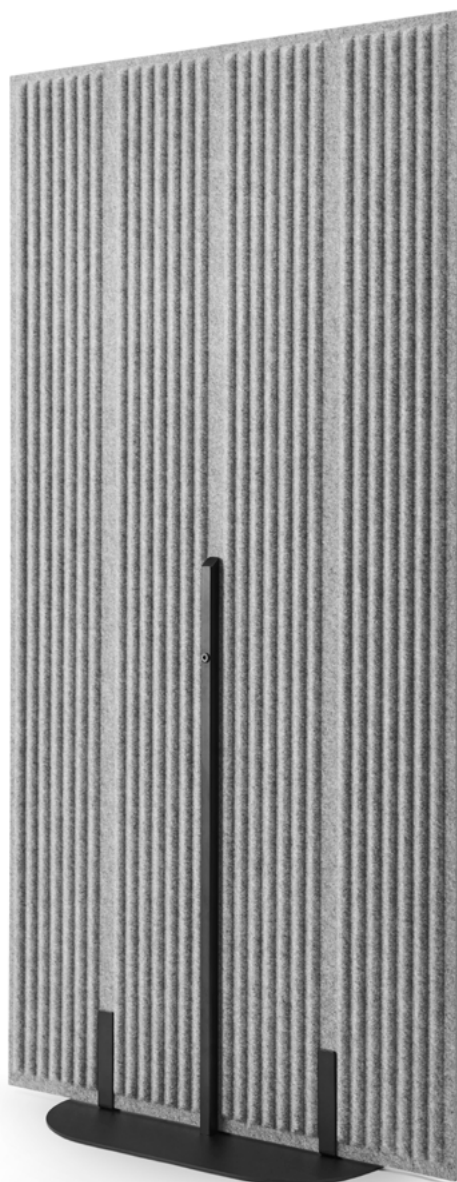
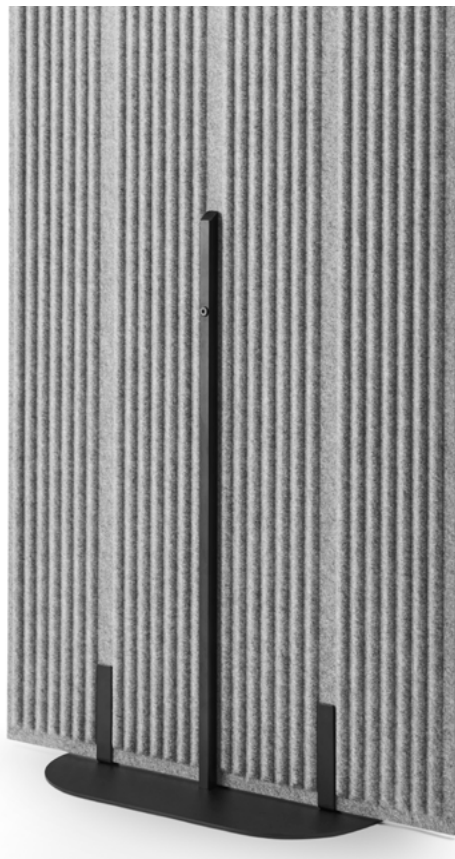
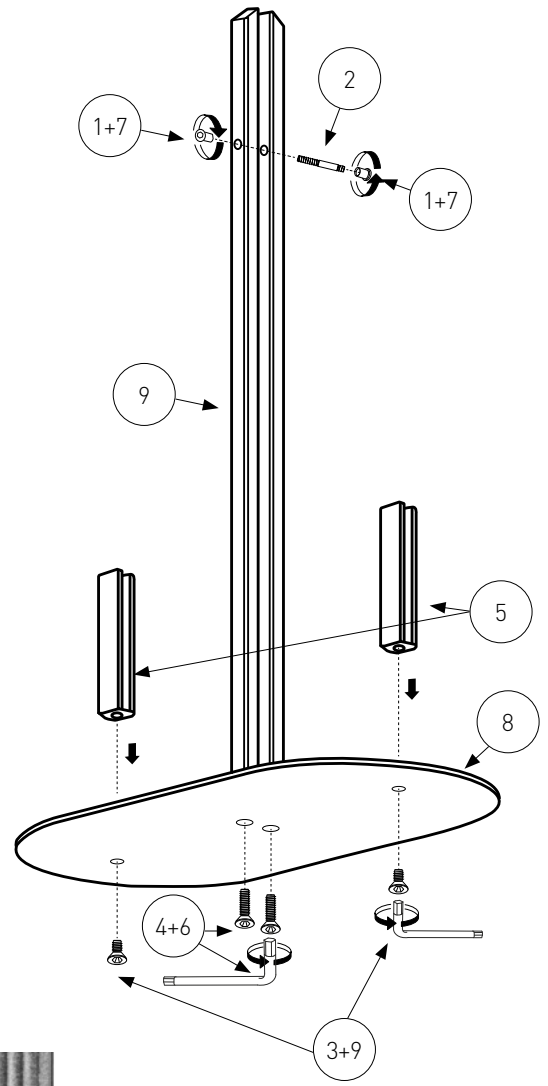
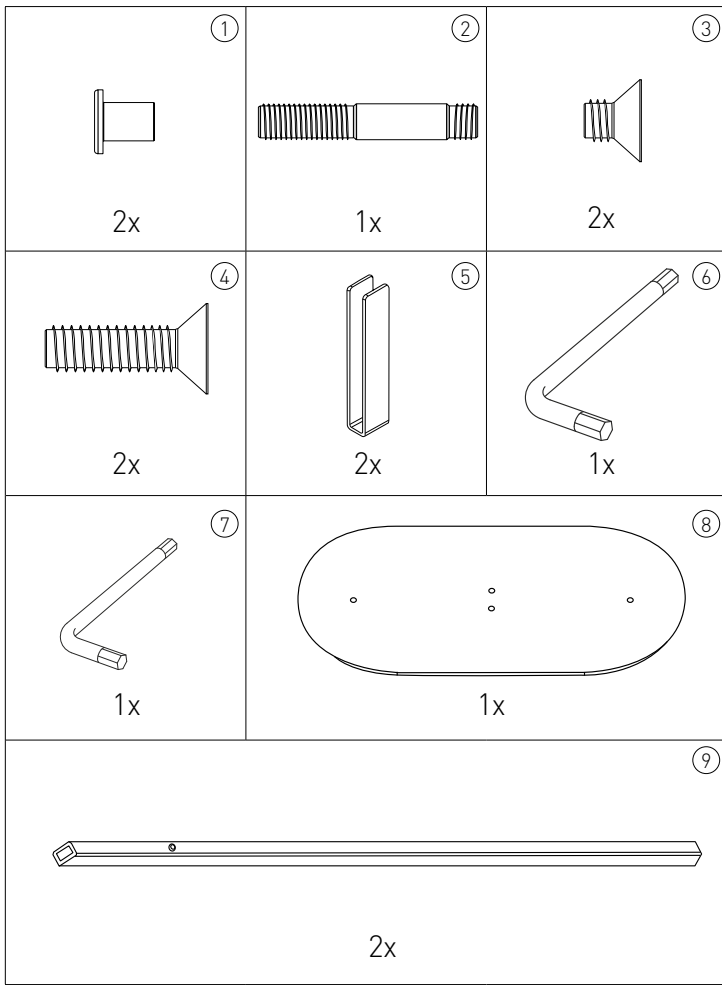



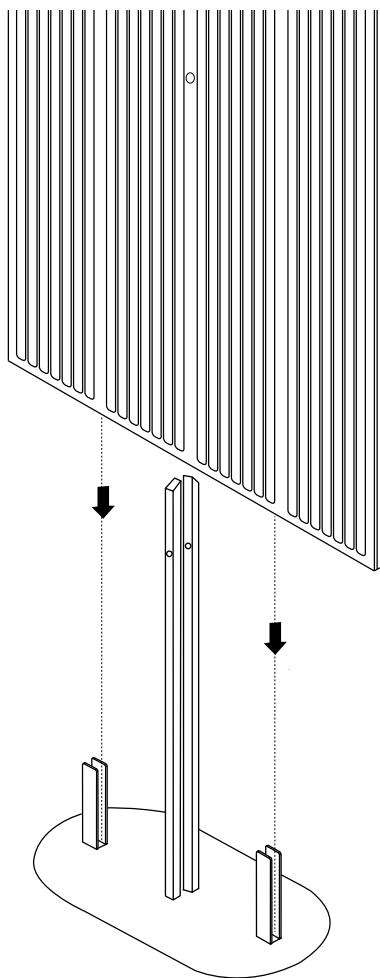

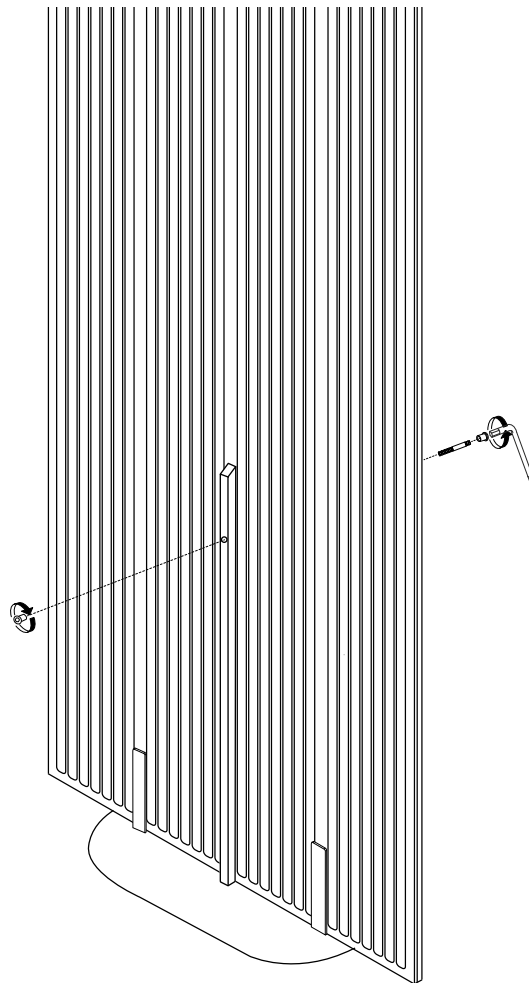

PL DODATKOWE INFORMACJE
Waga produktu – 13,45 kg.

EN ADDITIONAL INFORMATION
Product weight - 13.45 kg.

DE ZUSÄTZLICHE INFORMATIONEN
Produktgewicht – 13,45 kg.

RU ДОПОЛНИТЕЛЬНАЯ ИНФОРМАЦИЯ
Вес продукта: 13,45 кг.